



USB HID Accelerometer for StackableUSB™ USB1601



Features

- ✓ Tri-axis sensing for six degrees of freedom
- ✓ $\pm 8g$ sensitivity range
- ✓ Optional $\pm 50g$ or $\pm 200g$ fixed sensitivity ranges
- ✓ 10-bit and 12-bit sampling resolutions
- ✓ USB HID output for programming ease
- ✓ Small 1.85" x 1.74" board
- ✓ -40° to $+85^{\circ}C$ operation



The USB1601 adds tri-axis sensing on six degrees of freedom for any system that supports StackableUSB I/O modules. Featuring Freescale Semiconductor's MMA7455L accelerometer chip, the USB1601 is configured with a $\pm 8g$ sensing range. With the addition of the USB1601, the Host can easily determine roll, pitch, and yaw using clear-cut algorithms eliminating the need for an expensive Gyro.

The standard USB1601 is configured for low-g sensing range to enable higher resolution and detection of smaller movements. For applications needing medium-g or high-g ranges, the USB1601 can be configured for $\pm 50g$ or $\pm 200g$

sensitivities respectively. When choosing the appropriate g force, a 20% gap with respect to the highest g-force expected to be encountered in an application is recommended.

The USB1601 is USB 2.0 compliant and supports both full-speed (12Mbps) and low-speed (1.5Mbps) transfer rates. Acceleration measurements are streamed to the Host using USB generic HID protocol eliminating the need for custom USB drivers. To simplify programming, the USB1601 ships with sample software and full documentation and can be connected to desktop PCs and laptops via a Mini-B USB connector for development.

Software/Driver Support

Windows XP
Windows CE
Linux
Host MCU firmware
On-board MCU firmware
Sample software

Compatible Hardware

StackableUSB Host single board computers and microcontrollers
PC Host desktops and laptops

Mounting/Packaging

¼-Size 104™ Form Factor
Standoffs, STDOFFUSB

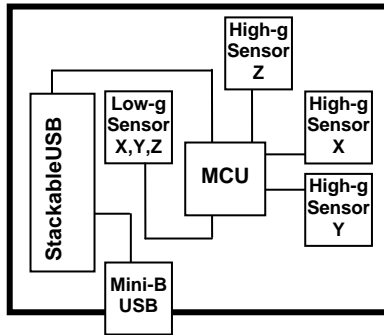

Specifications:

Mechanical:

- 1.85" x 1.74" StackableUSB
- ¼-Size 104™ Form factor

Power Requirements:

- +5v ±5%

Power Consumption with Options Installed (VDD = 5.0V)	
USB1601	45 mA
1601OPT2A	+5 mA
1601OPT2B	+5 mA
1601OPT3A	+5 mA
1601OPT3B	+5 mA
1601OPT4A	+5 mA
1601OPT4B	+5 mA

Environmental:

- 40° to +85°C operating temp
- 40° to +85°C storage temp
- 5%-95% relative humidity, non-condensing

Internal Electrical Interface:

- StackableUSB
- USB 1.1 & 2.0 compatible, full-speed

External Connectors:

- StackableUSB
- Mini-B USB

Development Kit:

- Base module
- Complete cable set
- Documentation, sample software

Accelerometers:

	USB1601-XX	1601OPT2	1601OPT3	1601OPT4
Freescalo Model	MMA7455L	A= MMA71213EG B= MMA1212EG	A= MMA2202EG B= MMA2301EG	A= MMA2202EG B= MMA2301EG
Sensing Planes	X, Y, Z	Z	Y	X
Range	±8g	A= ±50g B= ±200g	A= ±50g B= ±200g	A= ±50g B= ±200g
Max Acceleration (all axis)	±5000 g	±1500g (powered) ±2000g (unpowered)	±1500g (powered) ±2000g (unpowered)	±1500g (powered) ±2000g (unpowered)
Sensitivity	64 count/g (8g, 10 bit)	A= 32.76 count/g B= 8.19 count/g	A= 32.76 count/g B= 8.19 count/g	A= 32.76 count/g B= 8.19 count/g
Bandwidth Response	62.5 Hz,	400 Hz	400 Hz	400 Hz
Operating Voltage	3.3V	5V	5V	5V
Operating Current	0.5mA	5mA	5mA	5mA

Sensing Range:

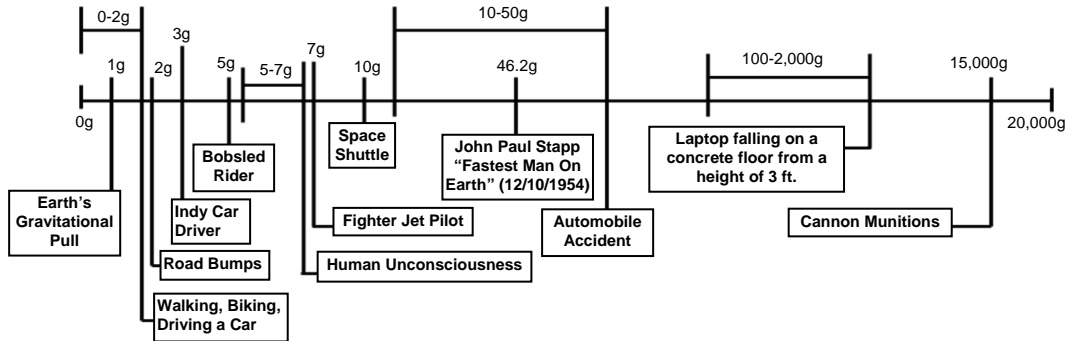

Ordering Information:

OEM Modules:

USB1601-ST	Accelerometer with StackableUSB stack-through connector; X, Y, Z sensing planes; $\pm 8g$
USB1601-PC	Accelerometer with Mini-B USB connector for PC connection; X, Y, Z sensing planes; $\pm 8g$
CS1601	Complete cable set
1601OPT2A	Z axis range $\pm 50g$
1601OPT2B	Z axis range $\pm 200g$
1601OPT3A	Y axis range $\pm 50g$
1601OPT3B	Y axis range $\pm 200g$
1601OPT4A	X axis range $\pm 50g$
1601OPT4B	X axis range $\pm 200g$

Related Products:

CA4136 A to Mini-B USB cable

Development Board Kits*

DK1601-ST	USB1601-ST development kit
DK1601-PC	USB1601-PC development kit