



Zigbee[®] Wireless Transceiver with Analog & Digital I/O for StackableUSB[™] USB1320



Features

- ✓ Point-to-Point, Point-to-Peer, Point-to-Multipoint, and Mesh topologies
- ✓ Xbee[®] ZB, Xbee-Pro[®] ZB, or Xbee-Pro[®] 900/DigiMesh[™] wireless modules
- ✓ FCC Certified
- ✓ Four (4) 10-bit analog in, two (2) PWM
- ✓ Seven (7) digital I/O
- ✓ Small 1.85" x 1.78" board
- ✓ -40° to +85°C operation



The USB1320 Zigbee Wireless Transceiver easily adds wireless communication to any StackableUSB Host computer or microcontroller. The USB1320 is ideal for rugged applications confined to small, tight spaces requiring reception in challenging environments. This small, easy-to-use USB module comes with sample software and full documentation.

Powered by the popular Digi[®] Xbee[®] modules, OEMs can select the wireless power that best matches their system's needs by selecting one of three Zigbee transceivers: the Xbee ZB, the Xbee-Pro ZB, or the Xbee-Pro 900/DigiMesh.

The USB1320 supports both API and transparent operation modes, allowing OEMs to choose between Point-to-Point, Point-to-Peer, Point-to-Multipoint, and Mesh networking topologies.

The 1.85" x 1.78" module is USB 2.0 compliant providing users the advantages of plug-and-play interfacing. The module stacks onto the top or bottom of any StackableUSB Host single board computer or microcontroller forming a small, rugged, embeddable system, ideal for harsh environments. The USB1320 can connect to desktop PCs and laptops via a Mini-B USB connector for easy development.

Software/Driver Support

Window XP
Windows CE
Linux
Host MCU firmware
Sample software

Compatible Hardware

StackableUSB Host single board computers and microcontrollers
PC Host desktops and laptops
ZB and Zigbee Pro devices
EmberZNet 2.5 devices

Mounting/Packaging

¼-Size 104[™] Form Factor
Standoffs, STDOFFUSB

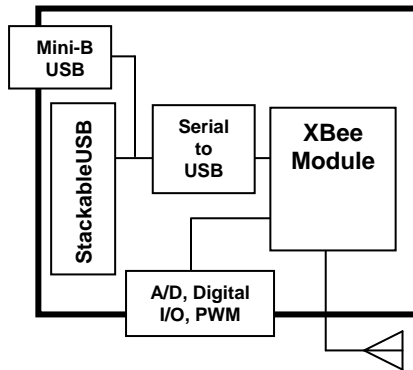

Technical Details:

| | USB1320-XX XBee® ZB | 1320OPT1-XX XBee-Pro® ZB | 1320OPT2-XX XBee-Pro 900/DigiMesh™ |
|--|--|--|---|
| Performance | | | |
| Indoor/Urban Range | Up to 133 ft (40 m) | Up to 300 ft (100 m) | Up to 450 ft (140m) |
| Outdoor RF Range <i>*With high gain ext. antenna</i> | Up to 400 ft (120 m) N/A | Up to 1 mile (1.6 km) N/A | Up to 1.8 miles (3 km) Up to 6 miles (10 km) |
| Transmit Power Output <i>*With boost mode</i> | 2 mW (+3dBm) 1.25 mW (+1dBm) | 50 mW (+17dBm) N/A | 50 mW (+17 dBm) N/A |
| RF Data Rate | 250 kbps | 250 kbps | 156.25 kbps |
| Serial Interface Data Rate <i>(software selectable)</i> | 1,200 – 230,400 bps | 1,200 – 230,400 bps | 1,200-230,400 bps |
| Receiver Sensitivity <i>*With boost mode</i> | -96 dBm -95 dBm | -102 dBm N/A | -100 dBm N/A |
| Power Requirements | | | |
| Supply Voltage | 2.1-3.6 VDC | 3.0-3.4 VDC | 3.0-3.6 VDC |
| Oper. Current (Max @ 3.3V) <i>*With boost mode</i> | 40 mA 35mA | 295 mA N/A | 210 mA (180 mA typical) N/A |
| Oper. Current (Rec. @ 3.3 V) | 15 mA | 15 mA | 80 mA |
| Power-down Current (@ 25°C) | < 1uA | < 10 uA | 60 uA |
| General | | | |
| Operating Frequency | ISM 2.4GHz | ISM 2.4GHz | ISM 902-928MHz |
| Dimensions | 0.960" x 1.087" (2.438cm x 2.761cm) | 0.960" x 1.297" (2.438cm x 3.294cm) | 0.962" x 1.312" (2.443cm x 3.332 cm) |
| Antenna | Chip | Chip | RPSMA |
| Spec. Order Antenna Opts | Int. Whip, RPSMA, U.FL | Int. Whip, RPSMA, U.FL | ¼ wave wire antenna U.FI |

| Network & Security | | | |
|-----------------------|--|--|--|
| Supported Topologies | Point-to-Point, Point-to-Multi-point, Peer-to-Peer, Mesh | Point-to-Point, Point-to-Multi-point, Peer-to-Peer, Mesh | Point-to-Point, Point-to-Multi-point, Peer-to-Peer, Mesh |
| Channels | 16 direct sequence | 13 direct sequence | 8 hopping on 12 direct sequences |
| Addressing Options | PAN ID & address, cluster IDs & endpoints | PAN ID & address, cluster IDs & endpoints | PAN ID, channel, 64-bit addresses |
| Certifications | | | |
| USA (FCC Part 15.247) | FCC ID: OUR-XBEE2 | FCC ID: MCQ-XBEEPRO2 | FCC ID: MCQ-XBEE09P |
| Industry Canada (IC) | IC: 4214A-XBEE2 | IC: 1846A-XBEEPRO2 | IC: 1846A-XBEE09P |
| Europe (CE) | ETSI | ETSI | N/A |
| RoHS | Compliant | Compliant | Compliant |

Specifications:

Mechanical:

- 1.85" x 1.78" StackableUSB
- ¼-size 104™ Form Factor

Power Requirements:

- +5V ±5%

| | Sleep | Typical | Max |
|----------|----------|---------|--------|
| USB1320 | 0.161 mA | 49 mA | 55 mA |
| 1320OPT1 | 0.161 mA | - | 185 mA |
| 1320OPT2 | 0.220 mA | 145 mA | 160 mA |

Above estimations are based on the assumptions that half of the wireless transactions are transmissions and the other half are receptions. Actual operating current will vary based on user application.

Environmental:

- 40° to +85°C operating
- 40° to +85°C storage

XBee Modules:

- Please see the *Technical Details* section.

Electrical Interfaces:

- StackableUSB
- USB 1.1 & 2.0 compatible, full-speed

I/O Ports:

- Four (4) 10-bit ADCs
- Seven (7) digital I/O
- Two (2) Pulse Width Modulators

Development Kit:

- Base Module
- Complete cable set
- Documentation, schematics, drivers, and sample software

External Connectors:

- StackableUSB
- Mini-B USB
- 14 pin I/O connector
- RPSMA ext. antenna connector (1320OPT2 only)

| 14 Pin I/O Connector | | | |
|----------------------|-----------|------------|-----|
| Pin | Signal | Signal | Pin |
| 1 | AD0/DIO0 | GND | 2 |
| 3 | AD1/DIO1 | GND | 4 |
| 5 | AD2/DIO2 | GND | 6 |
| 7 | AD3/DIO3 | GND | 8 |
| 9 | DIO4 | PWM0/DIO10 | 10 |
| 11 | PWM/DIO11 | GND | 12 |
| 13 | GND | GND | 14 |

Ordering Information

OEM Modules:

| | |
|------------|--|
| USB1320-ST | XBee ZB Wireless Transceiver with Analog & Digital I/O with StackableUSB stackthrough connector |
| USB1320-PC | XBee ZB Wireless Transceiver with Analog & Digital I/O with Mini-B USB connector for PC connection |
| CS1320 | Complete cable set |
| 1320OPT1 | XBee-Pro ZB wireless transceiver |
| 1320OPT2 | XBee-Pro 900/DigiMesh wireless transceiver |

Related Products:

| | |
|-----------|---------------------------|
| STDOFFUSB | StackableUSB standoff kit |
|-----------|---------------------------|

Development Board Kits*

| | |
|-----------|---|
| DK1320-ST | XBee ZB Wireless Transceiver with Analog & Digital I/O with StackableUSB stackthrough connector; Windows-ready development kit |
| DK1320-PC | XBee ZB Wireless Transceiver with Analog & Digital I/O with Mini-B USB connector for PC connection; Windows-ready development kit |

*See Development Kit Specifications