

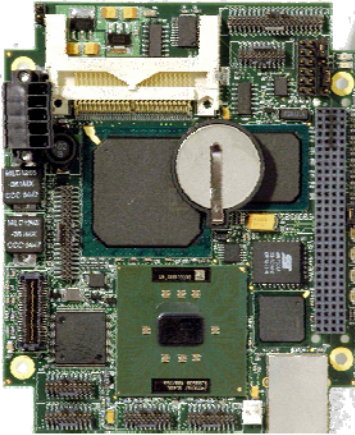

Celeron[®]/Pentium[®] III StackableUSB[™] Computer with Gigabit Ethernet SBC1685



Features

- ✓ Celeron/Pentium III processor, 400MHz, 650MHz, 933MHz
- ✓ Gigabit Ethernet
- ✓ Four (4) USB 2.0 high-speed ports, four (4) USB 1.1 ports as client and host
- ✓ Two (2) serial ports
- ✓ CompactFlash
- ✓ StackableUSB & PCI-104 expansion connectors



The SBC1685 packs a fast Pentium III or Celeron processor with advanced user interface capabilities onto a 3.775" x 4.55" x 1.2" size board supporting industry-standard mounting holes (PC/104 footprint). This powerful SBC includes a StackableUSB I/O expansion connector, enabling it to control up to ten StackableUSB peripheral boards in a stack plus SPI and I2C.

With up to 512Mbytes of SDRAM, most off-the-shelf PC programs execute effortlessly. When required, multiple gigabits of expansion memory are available through the CompactFlash connector.

The VGA interface on the SBC1685 supports CRT and DVO at resolutions up to 1600 x 1200. The SBC1685 has multiple serial communication channels for fast reliable data transfer, including Gigabit Ethernet, dual serial ports, and eight (8) host USB ports. The StackableUSB specification also provide for SPI and I2C expansion.

A wide variety of system-specific I/O can be plugged into the SBC1685 through the easy-to-use StackableUSB connector or the more complex PCI/104 interface connector.

Software/Driver Support

DOS emulation; MSDOS 6.22
Linux
Windows CE 6.0
Windows XP
C Language and BASIC C
Language

Expansion Hardware

StackableUSB Client devices
PCI -104 Client devices
RS232/RS485 devices
CompactFlash devices

Mounting/Packaging

Standoffs, STDOFFUSB
ENC104-4
PS756 wall mount
TB50110-550 terminal breakout
boards

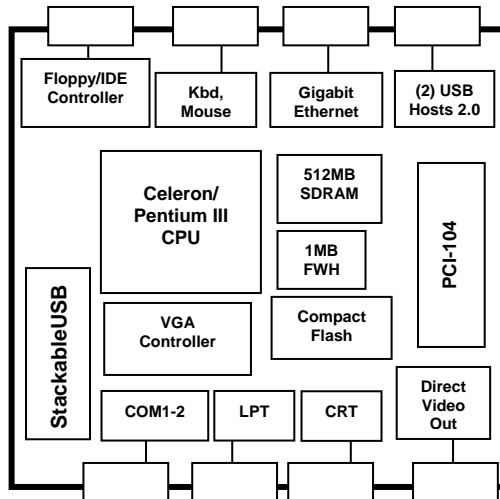

Technical Details:

The SBC1685 CPU core is built around the Intel Low Power Pentium III running at 933MHz, or the Ultra-Low Voltage Celeron processor running at 650 or 400MHz. Each CPU includes hardware floating point math and multimedia acceleration extensions.

The Pentium III and Celeron provide compatibility with both real mode and 32-bit protected mode programs. The SBC1685 incorporates the Intel 815E chipset, which integrates many PC-compatible peripherals. USB 1.1 ports, a battery-backed real time clock, an EIDE controller, two (2) cascaded 82C59A interrupt controllers, three (3) timer/counters (82C54 compatible), and a dual DMA controller are all included on the board from the 815E chipset.

The large memory subsystem on the SBC1685 enables many programs to be run without any external mass storage. The 512Mbytes of synchronous DRAM (SDRAM) executes complex, protected-mode PC-compatible programs and operating systems.

In systems where a large amount of memory is required there is a CompactFlash connector for

multi-gigabyte cards. The CompactFlash is used in the True IDE mode, where it is register-compatible with an EIDE hard drive, eliminating the need for special drivers in the operating system.

Display options on the SBC1685 include RGB, CRT, and DVO (direct video out). It also includes hardware acceleration for fast graphic updates. The video capability comes from the 815E chipset and supports resolutions up to 1600 x 1200.

For communication, the SBC1625 has two (2) serial ports, COM1 and COM2, that are 16C550 compatible UARTS with transmit and receive FIFOs. The COM ports running at speeds up to 11500 baud, have RS232 transceivers, RTS and CTS modem control lines. COM1 is configurable for half- or full-duplex RS485 communication with jumperable termination resistors. SPI and I2C are available through the StackableUSB connector.

Ethernet networking is supported with a 10/100/1000BASE-T Ethernet port that is compatible with any Ethernet network as a node or gateway.

The SBC1685 functions as a powerful front end processor for control applications providing two (2) stackable I/O expansion channels on the board. The first, StackableUSB, accommodates up to five (5) USB I/O boards on the top side and/or on the bottom side of the board without use of a hub. The other I/O expansion, PCI-104, is a 32-bit bus connector that supports plug-on cards that support the standard PC/104-Plus (PCI) bus protocol and timing.

Preinstalled firmware in the on-board flash includes a fully PC-compatible BIOS configured to support many operating systems and application programs. The BIOS setup allows users to configure the SBC1685 for different operating modes which includes setting disk parameters, console redirection, and interrupts. The BIOS can be customized for specific applications that require faster boot up times. Contact the factory for additional information on this feature.

The SBC1685 supports several different platforms for software development. Each board can be ordered and shipped with a pre-configuration software environment. SDKs (software development kit) should be specified on the initial order. If a specific SDK is not ordered, the board will ship configured with a generic DOS at no cost. There is a small royalty fee for upgrading to MSDOS 6.22.

For true 32-bit application development, the SBC1685 supports several operating systems. 32-bit real time operations systems (RTOS) such as Linux, PharLap ETS, QNX, and VxWorks are compatible with the SBC1685. All these operating systems support 32-bit linear protected mode operation and have full tool suites available, including compilers and debuggers. For Microsoft developers, the SBC1685 will run Windows CE and Windows XP in various configurations from the factory.

For OEM users, Micro/sys will pre-configure boards in production quantities with specified options and configurations and a single part number for easy ordering and version control. In addition, custom versions of the SBC1685 are available. Please contact Micro/sys Technical Sales for details.

Specifications:

Mechanical:

- PC/104 mounting holes
- 3.775" x 4.55" x 1.2"
- Installed CompactFlash card extends past edge of board

Power Requirements:

- All versions require +5v \pm 5%
- SBC1685 (400Mhz) at 3.3A max
- SBC1685 (650Mhz) at 4.1A max
- SBC1685 (933Mhz) at 4.5A max
- +12v required only if used by expansion modules or flat-panel displays

Environmental:

- SBC1685, SBC1685-650 includes a factory-installed CPU heat sink
- SBC1685-933 includes a factory-installed heat sink/fan
- 40° to +85°C storage
- 5%-95% relative humidity, non-condensing

Processor Core Section:

- Intel Celeron or Pentium III
- 400, 650, 933MHz clock rate
- Hardware floating-point math
- AT-compatible timers, interrupts, DMA

On-board Memory:

- 256MB Synchronous DRAM based at address 0

Watchdog Timer:

- Program must refresh watchdog timer periodically, or system will be reset
- Enabled through software

PCI-104 Interface:

- Non-stackthrough PCI-104 connector
- Full 32-bit PCI-type transfers supported
- Stackthrough option available (SBCOPT120ST)

SVGA Video Output:

- CRT and DVO outputs
- Resolutions to 1600 x 1200

COM1-COM2 Serial Ports:

- Two (2) async serial ports, PC compatible
- 16550-compatibility
- RTS and CTS modem controls
- RS232 signal levels

Keyboard, Mouse, and Speaker:

- PS/2-compatible keyboard port
- PS/2-type mouse port
- AT-compatible TTL speaker output

Real Time Clock:

- RTC with on-board battery
- Driver software in BIOS

USB:

- Four (4) USB 2.0 ports
- Transfers at high-speed 480Mbit/sec, full-speed 12Mbit/sec, or 1.5Mbit/sec
- Four (4) USB 1.1 ports
- Transfers at 12Mbit/sec or 1.5Mbit/sec

Floppy Disk Interface:

- Two (2) drives on a single cable
- Standard connector pinout

IDE:

- One connector with two (2) drives on each cable (CompactFlash counts as one drive) for a total of four (4) drives
- Hard drive, CD-ROM support
- Flexible BIOS drive setup

Parallel Printer Port:

- Bi-directional LPT standard

CompactFlash Interface:

- Supports Type I CompactFlash
- Operates in True IDE mode
- CF+ cards not supported
- Not hot-swappable

External Connections:

- 40-pin high-density header for IDE
- 20-pin high-density header for USB
- 20-pin high-density header for COM1-COM2 RS232/ COM1 RS485
- 20-pin high-density header for CRT, keyboard, mouse, and speaker
- 40-pin high-density header for DVO
- 20-pin high-density header for parallel port
- 20-pin high-density header for floppy
- 5-pin removable terminal strip for power input

Development Kit:

- SBC with all options installed
- Complete cable set
- Documentation, schematics, sample software

Ordering Information:

OEM Single Board Computers:

SBC1685	Celeron CPU, 400MHz, 128MB RAM, VGA
SBC1685-1	Celeron CPU, 400MHz, 128MB RAM, VGA, 10/100/1000 BASE-T Ethernet
SBC1685-650	Celeron CPU, 650MHz, 128MB RAM, VGA
SBC1685-650-1	Celeron CPU, 650MHz, 128MB RAM, VGA, 10/100/1000 BASE-T Ethernet
SBC1685-933	Pentium III CPU, 933MHz, 128MB RAM, VGA
SBC1685-933-1	Pentium III CPU, 933MHz, 128MB RAM, VGA, 10/100/1000 BASE-T Ethernet
CS1685	Complete cable set
1685OPT1	256MB of RAM
1685OPT2	512MB of RAM
1685OPT25	MS-DOS in CompactFlash

Related Products:

BA2018	Breakout cable to two DB9 COM port connectors
BA1616	CRT/Mouse/Keyboard Breakout Cable
BA4040	IDE Breakout Cable
BA2034	Floppy Breakout Cable
BA2025	LPT Breakout Cable
SBCOPT120ST	PCI-104 Stackthrough Option, 120-pin
CF-FL128	128MB CompactFlash Card
CF-FL256	256MB CompactFlash Card
CF-FL512	512MB CompactFlash Card
USB3368	8 port USB adapter board with StackableUSB stackthrough connector

*Cables nominally 15", other lengths available.
CommBLOK, PidBLOK trademark Drumlin
IBM, PC trademark IBM Corp.
MSDOS, Microsoft trademark Microsoft Corp.
VxWorks trademark Wind River
Pentium, Celeron trademark Intel Corp.*

Development Board Kits*

DK1685-1	Celeron CPU, 400MHz, 128MB RAM, VGA, 10/100/1000 BASE-T Ethernet, Windows- ready development kit
DK1685-650-1	Celeron CPU, 650MHz, 128MB RAM, VGA, 10/100/1000 BASE-T Ethernet, Windows- ready development kit
DK1685-933-1	Pentium III CPU, 933MHz, 128MB RAM, VGA, 10/100/1000 BASE-T Ethernet, Windows-ready development kit

**See Development Kit Specifications*