



# 486/586 PC/104 Computer with CompactFlash and Flat Panel SBC1495



## Features

- ✓ Ready to run 486/586 computer
- ✓ 120 or 133MHz
- ✓ CRT and flat panel output
- ✓ 64MB SDRAM
- ✓ CompactFlash connector
- ✓ 10/100BASE-T Ethernet
- ✓ Two serial ports
- ✓ Extended temperature available

The SBC1495 packs a fast 486DX processor with plenty of memory, and copious amounts of storage into a PC/104-sized board. Both CRTs and color TFT flat panels are supported by the built-in VGA interface. Additional I/O includes six LVTTTL digital I/O lines, dual serial ports, USB, EIDE, LPT, keyboard, and mouse.

In its stackthrough version, the SBC1495 is an ideal computer to plug into a custom OEM I/O card. Immediately and easily, an advanced engine is available for software development.

With 1MB of on-board flash, accessible as a read/write disk, and 64MB of SDRAM, many large programs can be run. However, if additional storage capacity is required, the CompactFlash connector allows hundreds of megabytes of removable program and data storage.

If additional capabilities are needed, PC/104 expansion allows a wide variety of I/O cards to be stacked on the SBC1495.

### Software Support

*DOS* emulation  
*MSDOS 5.0*  
*Linux*  
*Windows CE*  
*RTOS*  
*Comm Library, CommBLOK™*  
*PID loop library, PidBLOK™*  
*C, compilers*  
[Items above in Section 6]

### Compatible Hardware

*PC/104 expansion cards*  
[Items above in Section 4]  
*RS232/RS485 devices*  
*Custom*

### Mounting/Packaging

*Standoffs, STDOFF01*  
[Items above in Section 5]  
*Custom*

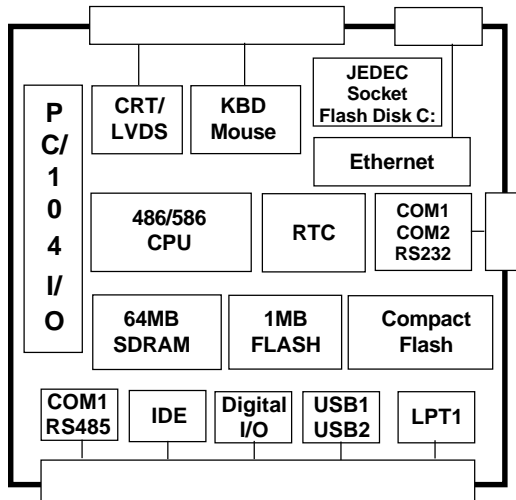

## Technical Details:

The SBC1495 core is an ST Microelectronics STPC Atlas processor running at 120 or 133 MHz. The STPC 486DX processor core is clocked at a rate of 133MHz, and includes hardware floating point math. While other 486DX systems access RAM with a 32-bit data bus, the Atlas accesses RAM with a 64-bit wide data bus, offering performance similar to low-end Pentium-based designs.

The Atlas allows compatibility with both real mode and 32-bit protected mode programs. The Atlas also integrates many PC-compatible peripherals. Dual USB ports, a keyboard and mouse controller, an EIDE controller, two cascaded 82C59A interrupt controllers, dual 16C550 UARTs, three timer/counters (82C54 compatible), and a dual DMA controller are all present. A hardware accelerated VGA controller, with support for both CRTs and TFT panels, is also implemented.

The memory subsystem on the SBC1495 allows many programs to be run without any external storage. 64 Mbytes of synchronous DRAM (SDRAM) is more than sufficient for many complex, protected-mode programs and operating systems.

The 1-Mbyte Flash memory chip contains both the BIOS and a user application code space. The user space can be configured as a 768k read/write flash disk.

If a larger program or data storage space is required, or if removability is needed, the CompactFlash interface can provide hundreds of megabytes of storage. CompactFlash is used in the True IDE mode, where it is register compatible with an EIDE hard drive. Thus, it does not require any special drivers for most operating systems.

The user byte-wide socket can accept a number of different devices. EPROM, 5v Flash, DiskOnChip®, or SRAM can all be plugged in. The SRAM can be battery-backed, which makes for fast storage for data that is updated often.

The VGA controller supports resolutions up to 1280 x 1024 (CRT) or 1024 x 1024 (programmable panel). It includes hardware acceleration for fast graphic updates. The output can drive a standard RGB CRT monitor, and an LCD flat panel display. Active matrix (TFT) LCD panels are supported, in 18-bit color. The LVDS interface is compatible with many displays and ensures that the signal integrity is maintained.

Two serial ports allow communication with many different devices. COM1 and COM2 are 16C550-compatible UARTs (with transmit and receive FIFOs). These serial ports are capable of speeds up to 115200 baud, have RS-232 transceivers, and have RTS and CTS modem control lines. Additionally, COM1 is configurable for half-duplex RS-485 communication with jumperable termination resistors.

The PC/104 connector provides support for both 8-bit and 16-bit expansion boards and operates with standard PC/104 bus protocol and timing. The default configuration is non-stackthrough connectors, allowing the SBC1495 to be the bottom card in a stack. The stackthrough option (SBCOPT16ST) allows the SBC1495 to be plugged into a custom-designed OEM I/O board as an automation component.

The SBC1495 can support application development under numerous strategies. If 16-bit DOS or DOS-extended software is sufficient, Micro/sys offers a free DOS-compatible operating system preinstalled on the SBC1495. For a small royalty fee, true MSDOS 5.0 can be preinstalled. Powerful, cost-effective remote debug capabilities are provided through Borland's Turbo Debugger.

For true 32-bit application development, the SBC1495 supports a number of alternatives. Due to its PC compatibility, 32-bit real time operating systems (RTOS) such as PharLap® ETS, and VxWorks® can be booted on the SBC1495. All support 32-bit linear protected mode operation, and have full tool suites available, including compilers and debuggers.

The firmware suite that is preinstalled in flash on the SBC1495 includes an industrial BIOS that allows configuration of many of its features. In addition to allowing configuration of the normal PC-compatible peripherals such as floppy drives and hard drives, it allows 768k of the system flash to be used as a read/write wear-leveled flash drive. Another feature of the BIOS is its ability to redirect the console out COM1, COM2, or the VGA/keyboard so that even "headless" systems can have a user console when needed for configuration or debug.

For pre-configured sets of options, Micro/sys can provide OEMs with a single part number for ordering. In addition, custom versions of the SBC1495 are available. Please call Micro/sys Technical Sales for details.

## ***Specifications:***

### **Mechanical:**

- PC/104 standard
- 3.55" (plus I/O region) x 3.775" x .6"
- Installed CompactFlash card extends past edge of board opposite the PC/104 connector
- If installed, Ethernet connector on top side has height of .535"

### **Power Requirements:**

- +5v ±5% at 1.3A typical, 1.8A max.
- +12v required only if used by PC/104 modules

## Environmental:

Part number	Board Airflow*	Operating Temp
SBC1495-1	0 cfm	0° to +48°C
SBC1495-1	17 cfm	0° to +70°C
SBC1495-ET	0 cfm	-40° to +85°C
SBC1495-1-ET	0 cfm	-40° to +85°C

\*Using 80mm fan

- 40° to +85°C storage
- 5%-95% relative humidity, non-condensing

## Processor Core Section:

- STPC Atlas CPU
- 120 or 133 MHz clock rate
- Hardware floating point math
- AT-compatible timers, interrupts, DMA

## On-board Memory:

- 64MB Synchronous DRAM based at 0
- 1M of Flash at top of memory map with BIOS and operating system installed; 768k available for user application
- JEDEC 32-pin socket for 128k/512k SRAM for battery-backed RAM, or DiskOnChip®

## Watchdog Timer:

- Program must refresh watchdog timer periodically, or system will be reset
- Enabled through software

## Keyboard, Mouse, and Speaker:

- PS/2-compatible keyboard port
- PS/2-stype mouse port
- AT-compatible TTL speaker output

## SVGA Video Output:

- CRT and color LCD outputs
- Resolutions to 1280 x 1024 (CRT) or 1024 x 1024 (programmable panel)
- Direct connect to TFT flat panels
- 3.3V 18-bit panel color support
- LVDS (PanelLink/FPD-Link) drivers

## COM1-COM2 Serial Ports:

- Two async serial ports, PC compatible
- 16550-compatible
- RTS and CTS modem controls
- RS232 on both channels
- COM1 RS485 half duplex

Serial Port Connector			
Pin	Signal	Signal	Pin
1	RX COM1	RTS COM1	2
3	TX COM1	CTS COM1	4
5	-	-	6
7	GND	RX COM2	8
9	RTS COM2	TX COM2	10
11	CTS COM2	-	12
13	-	GND	14

## Digital I/O:

- Six LVTTTL bi-directional signals
- 5v-tolerant

User Interface Connector			
Pin	Signal	Signal	Pin
1	GND	TXCLK+	2
3	TXCLK-	GND	4
5	TXOUT2+	TXOUT2-	6
7	GND	TXOUT1+	8
9	TXOUT1-	GND	10
11	TXOUT0+	TXOUT0-	12
13	GND	GND	14
15	TFT VCC	TFT VCC	16
17	TFT PWM	TFT EN5V	18
19	GND	GND	20
21	MOUSE CLK	MOUSE DTA	22
23	+5V	+5V	24
25	KBD DTA	KBD CLK	26
27	SPKR	-	28
29	-	I2C CLK	30
31	I2C DTA	HSYNC	32
33	GND	VSYNC	34
35	GND	BLUE	36
37	GND	GREEN	38
39	GND	RED	40

## Parallel Port:

- Bi-directional LPT standard

Main I/O Connector			
Pin	Signal	Signal	Pin
A1	GND	IDE RESET#	B1
A2	USB D0-	GND	B2
A3	USB D0+	IDE D7	B3
A4	USB VCC	IDE D8	B4
A5	GND	IDE D6	B5
A6	USB D1-	IDE D9	B6
A7	USB D1+	IDE D5	B7
A8	USB VCC	IDE D10	B8
A9	GND	IDE D4	B9
A10	GPIO0	IDE D11	B10
A11	GPIO1	IDE D3	B11
A12	GPIO2	IDE D12	B12
A13	GPIO3	IDE D2	B13
A14	GPIO4	IDE D13	B14
A15	GPIO5	IDE D1	B15
A16	GND	IDE D14	B16
A17	-	IDE D0	B17
A18	GND	IDE D15	B18
A19	RS485+	GND	B19
A20	RS485-	-	B20
A21	+5V	IDE DRQ	B21
A22	LPT STB#	GND	B22
A23	LPT AFD#	IDE IOW#	B23
A24	LPT D0	GND	B24
A25	LPT ERR#	IDE IOR#	B25
A26	LPT D1	GND	B26
A27	LPT INIT#	IDE IORDY	B27
A28	LPT D2	GND	B28
A29	LPT SLIN#	IDE DACK#	B29
A30	LPT D3	GND	B30
A31	GND	IDE IRQ	B31
A32	LPT D4	IDE IO16#	B32
A33	LPT D5	IDE DA1	B33
A34	LPT D6	IDE PDIAG#	B34
A35	LPT D7	IDE DA0	B35
A36	LPT ACK#	IDE DA2	B36

#### Real Time Clock:

- RTC with on-board battery
- Driver software in BIOS

#### PC/104 Interface:

- Non-stackthrough PC/104 connectors
- Standard mounting holes
- 8-bit and 16-bit PC/104 module support

- Full IRQ and DRQ support
- Stackthrough option available (SBCOPT16ST)

#### CompactFlash Interface:

- Supports Type I CompactFlash
- Operates in True IDE mode
- CF+ cards not supported
- Not hot-swappable

Power Connector	
Pin	Signal
1	+5V
2	+12V
3	GND

#### DK1495 Development Kit:

- Free with first SBC1495 purchase
- Breakout cable to COM1-COM2
- Breakout cable to IDE, USB, LPT, digital I/O
- Breakout cable to CRT, keyboard, mouse, speaker
- Download cable and utilities
- Documentation, schematics, sample software

#### External Connections:

- 80-pin connector for IDE, USB, LPT, and digital I/O
- 14-pin header for COM1-COM2
- 40-pin header for CRT, flat panel, keyboard, mouse, speaker
- 3-pin removable terminal strip for power input

### Ordering Information:

#### Single Board Computer:

SBC1495	486/586 CPU, 133MHz, 64MB RAM, 1M Flash
SBC1495-1	486/586 CPU, 133MHz, 64MB RAM, 1M Flash, 10/100BASE-T Ethernet

SBC1495-ET	486/586 CPU, 120MHz, 64MB RAM, 1M Flash, -40 to +85C operating temperature
SBC1495-1-ET	486/586 CPU, 120MHz, 64MB RAM, 1M Flash, 10/100BASE-T Ethernet, -40 to +85C operating temperature
DK1495	No charge development kit, available with first order only
SDK Linux	Linux Kit (requires Ethernet and 1495OPT50)
1495OPT25	MSDOS 5.0 in Bootable A: Flash Disk
1495OPT28	Color TFT (LVDS) panel support
1495 OPT50	Linux startup kernel installed in flash

#### **Related Products:**

CA4089	Breakout cable to two DB9 COM port connectors
CA4097	Breakout cable for EIDE, USB, LPT, Digital I/O
CA4098	Breakout cable for CRT, Kbd, mouse, speaker, TFT panel
RAM128	128k RAM device
RAM512	512k RAM device
SBCOPT16ST	Stackthrough PC/104
CF-FL128	128MB CompactFlash Card
CF-FL256	256MB CompactFlash Card
CF-FL512	512MB CompactFlash Card

Cables nominally 15", other lengths available

CommBLOK, PidBLOK trademark Drumlin  
 IBM, PC trademark IBM Corp.  
 MSDOS, Microsoft trademark Microsoft Corp.  
 Turbo Debugger trademark Borland International  
 DiskOnChip trademark M-Systems