

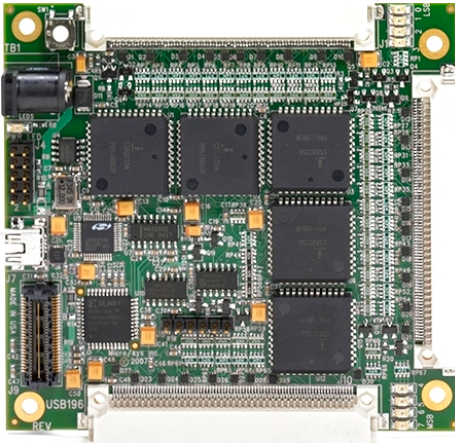

High-Density Digital I/O for StackableUSB™ USB196



Features

- ✓ 96 user controllable TTL-level I/O lines
- ✓ Timers/Counters, switches/LEDs
- ✓ 10-bit single-ended/differential A/D
- ✓ Two RS232 serial ports, 1 each I2C and SPI bus interfaces
- ✓ StackableUSB 2.0 device with stack together connectors for embedded systems or plug/cable configuration for remote applications



The USB196 operates as a USB 2.0 Full-speed device in a StackableUSB system or connected to a PC using a standard USB cable. Four 82C55's provide bi-directional general system I/O. In addition, the USB196 includes 2 RS232 serial ports, 1 I2C and SPI bus interface, a 16 bit counter with a capture/compare input, a single comparator, and a 10-bit A/D converter. The USB196 provides this wealth of system I/O on a small 3.55 x 3.755 footprint.

The USB interface, in the stackable or cable configuration, allows the USB196 to be added into any USB system by using the standard USB

“plug and play” hardware and software configuration after installing the software provided for the host computer. This significantly simplifies user's system integration.

The USB196 implements many features to enhance system reliability. Grounds are placed between most 82C55 signals. Software programmable pull ups/downs on each I/O line provide deterministic reset levels. The USB196 protects against power sequencing issues with other boards in the stack or system by providing resistors on all I/O lines.

Software Support

- Windows XP
- Windows CE
- Linux

Compatible Hardware

- StackableUSB
- PC host

Mounting/Packaging

- ENC104-4
- Standoffs, STDOFFUSB

[Items above in Section 5]

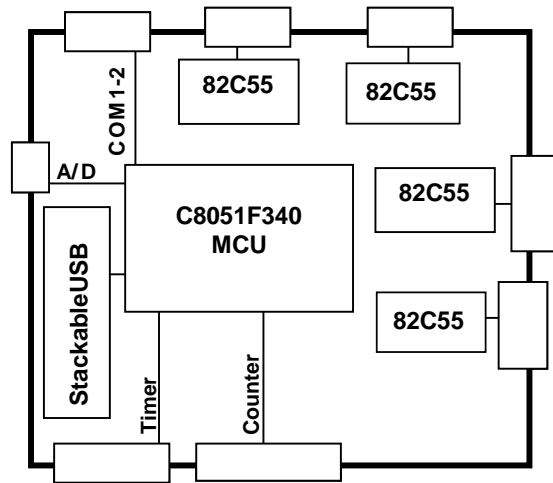

Technical Details:

Four 82C55 digital I/O devices provide 96 lines of TTL I/O. Direction of the I/O signals is programmable in two 8-bit groups and two 4-bit groups for each 82C55. The 82C55 TTL I/O lines can source and sink at 2.5mA.

The USB196 comes with pre-installed software that allows the transfer of data between the USB port and all of the onboard peripherals with no need to write additional code on the USB196 device side of the system. To ease installation of the USB196 on the host side, USB drivers and example source code are supplied, eliminating the need for prior experience USB experience. Host side operating systems supported are Linux, Windows CE, and Windows XP.

A command and control protocol implemented over the USB interface allows direct communication with the onboard peripherals via import and output driver calls executed on the host computer. Custom interrupt service routine can be called directly by the host side USB driver.

The USB196 utilizes a microcontroller with a built-in USB device controller which acts as the

communication channel between the on-board peripherals and the StackableUSB host computer. The USB196 is USB 2.0 compatible and supports both full-speed (12 Mbps) and low-speed (1.5 Mbps) transfer rates.

Other peripherals coming from the microcontroller include a single-ended or differential input A/D with a range of 0 to 3.3V. Conversions can be triggered from timers or from an external pin. There are two serial ports, COM1 and COM2, configured with RS232 transceivers with the TXD and RXD lines supported. Other system level housekeeping functions included on the USB196 is an interrupt controller, and a watchdog timer.

The onboard microcontroller includes 64k of flash, and 4352 bytes of SRAM which allows users to write board specific control routines for the USB196. Most instructions are executed in one or two system clock cycles, allowing the MCU to achieve performances as high as 48 MIPS. This feature can off load the host CPU of service routines, reserving the USB communication link for sending system level commands rather than directly controlling each event.

The StackableUSB bus architecture allows up to five USB peripheral boards to be stacked above and/or below a single board computer or hub board, making ten board systems with any combination of StackableUSB boards possible without the use of a hub. Please call Micro/sys Technical Sales for details.

Specifications:

Mechanical:

- 104 form factor standard
- 3.55" (plus I/O region) x 3.775"x .6"

Power Requirements:

- +5v \pm 5% at 320mA max

Environmental:

- Operating range 0° to +70°C
- ET-version operating range -40° to +85°C
- 40° to +85°C storage
- 5%-95% relative humidity, non-condensing

Microcontroller Core Section:

- Silicon Laboratories 8051
- 48 MHz clock rate
- Optimized 8051 instruction set
- 64 kbytes of flash memory
- 4352 bytes of SRAM

USB Interface:

- USB 2.0 full-speed
- USB device or function controller only (Controller does not operate as a host)

Serial Ports:

- Two (2) async serial ports
- RS232 levels
- TXD and RXD signals supported for both ports

SMBus/I2C Port:

- Configurable as master or slave
- Clock speeds up to 4.8 MHz

SPI bus:

- Single master single slave only
- Clock speeds up to 12.5 MHz

Analog Input:

- 10-bit resolution, successive-approximation register ADC
- 0 to 3.3V range
- Conversion starts from timer or external pin
- 200Ksps
- Single-ended or differential inputs

Watchdog Timer:

- Program must refresh watchdog timer periodically, or system will be reset
- Enabled through software

Debug/Download Interface:

- Silicon Laboratories 2-wire C2 interface
- Allows programming of program flash or debugging of user application

Digital I/O:

- Four (4) 82C55s provide 96 lines of TTL-level digital I/O, 2.5mA source/sink
- Software-configurable pull ups/downs on I/O for initialization after reset
- 470-ohm current limiting resistors
- Individual grounds for all signals

External Connections:

- 14-pin header for COM1-COM2
- Four 50-pin headers for digital I/O
- 10-pin header for debug/download
- 34-pin header for MCU signals (ADC, timers, DIO, I2C, comparators)
- 2-pin removable terminal strip for +5V power

Ordering Information:

USB196	DIO, Timer Board for StackableUSB
USB196-ET	DIO, Timer Board for StackableUSB, -40° to +85°C operating temperature

Related Products:

CA4089	Breakout cable to two DB9 COM port connectors
BA4089	Breakout assembly to two DB9 COM port connectors
BA0050	50-pin to 50-pin ribbon cable with 50-point Screw Terminal Breakout Board
BA0034	34-pin to 34-pin ribbon cable with 34-point Screw Terminal Breakout Board
CA5049	50-pin to 50-pin ribbon cable
CA5050	34-pin to 34-pin ribbon cable

Cables nominally 15", other lengths available